

## CALIFORNIA

## Standards Preview

**S 8.2** Unbalanced forces cause changes in velocity. As a basis for understanding this concept:

- e. Students know that when the forces on an object are unbalanced, the object will change its velocity (that is, it will speed up, slow down, or change direction).

**S 8.8** All objects experience a buoyant force when immersed in a fluid. As a basis for understanding this concept:

- c. Students know the buoyant force on an object in a fluid is an upward force equal to the weight of the fluid the object has displaced.
- d. Students know how to predict whether an object will float or sink.

**S 8.9** Scientific progress is made by asking meaningful questions and conducting careful investigations. As a basis for understanding this concept and addressing the content in the other three strands, students should develop their own questions and perform investigations. Students will:

- a. Plan and conduct a scientific investigation to test a hypothesis.
- c. Distinguish between variable and controlled parameters in a test.
- f. Apply simple mathematical relationships to determine a missing quantity in a mathematic expression, given the two remaining terms (including  $\text{speed} = \text{distance}/\text{time}$ ,  $\text{density} = \text{mass}/\text{volume}$ ,  $\text{force} = \text{pressure} \times \text{area}$ ,  $\text{volume} = \text{area} \times \text{height}$ ).

The force of air pushing on a hang glider's wing helps to keep the glider aloft. ►







## Video Preview

Discovery Channel School

*Forces in Fluids*



Focus on the  
**BIG Idea**



S 8.8.d

How can you predict if an object will sink or float in a fluid?

### Check What You Know

You dive into a pool wearing a life vest. Wearing the vest makes you bigger and makes you weigh more. So why do you float?





# Build Science Vocabulary

The images shown here represent some of the Key Terms in this chapter. You can use this vocabulary skill to help you understand the meaning of some Key Terms in this chapter.

## Vocabulary Skill

### Identify Multiple Meanings

Some familiar words have more than one meaning. Words you use every day may have different meanings in science. Look at the different meanings of the words below.

Word	Everyday Meaning	Scientific Meaning
<b>fluid</b>	<i>n.</i> A liquid <b>Example:</b> It's good for your health to drink plenty of <u>fluids</u> every day.	<i>n.</i> A substance that can easily flow; a gas or a liquid <b>Example:</b> Like water, air is a <u>fluid</u> .
<b>force</b>	<i>v.</i> To use power to make someone do something <b>Example:</b> She had to <u>force</u> herself to get up early.	<i>n.</i> A push or a pull exerted on an object <b>Example:</b> You exert <u>force</u> when you open and close a door.
<b>pressure</b>	<i>n.</i> A feeling of being pushed to do things <b>Example:</b> Students may feel <u>pressure</u> from adults to do well on tests.	<i>n.</i> The force exerted on a surface divided by the total area over which the force is exerted <b>Example:</b> When air leaks from a tire, the <u>pressure</u> is reduced and the tire becomes soft.

### Apply It!

Read the sentences below. Then identify the term that has a scientific meaning.

1. When a gas is heated, the *pressure* of the gas increases.
2. Her parents are putting *pressure* on her to find a job.





# Chapter 11 Vocabulary

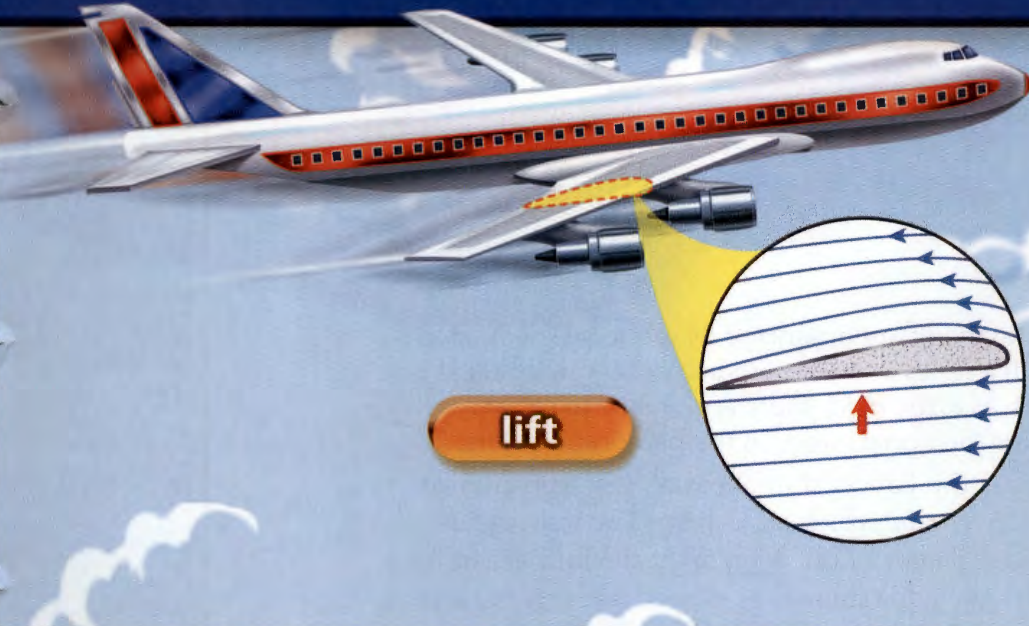

## Section 1 (page 416)

pressure  
pascal  
fluid  
barometer

## Section 2 (page 424)

density  
buoyant force  
Archimedes' principle

## Section 3 (page 432)

Pascal's principle  
hydraulic system

## Section 4 (page 437)

Bernoulli's principle  
lift

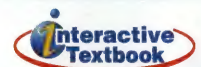
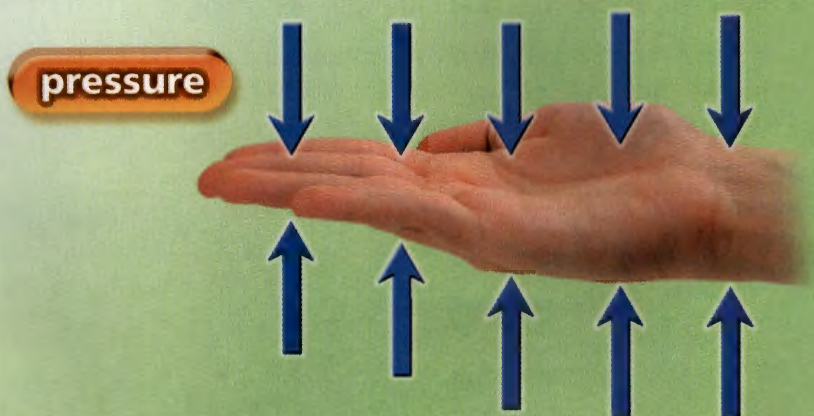
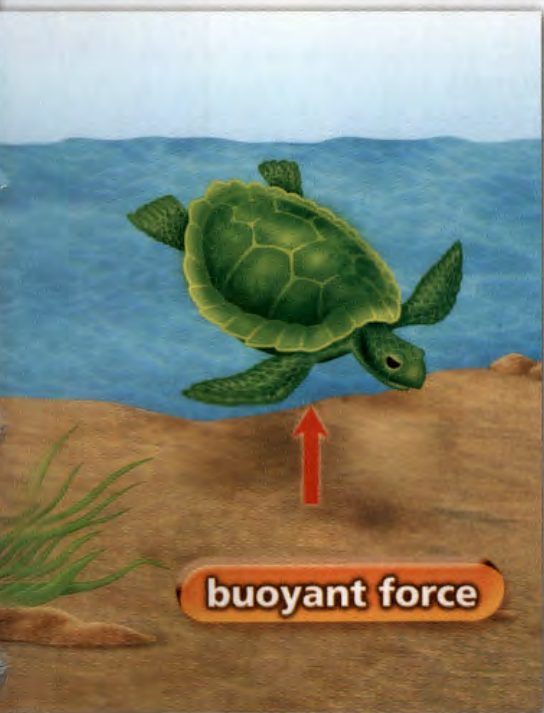

**Build Science Vocabulary  
Online**

Visit: [PHSchool.com](http://PHSchool.com)  
Web Code: cxj-3110



# How to Read Science

## Reading Skill



### Sequence

Many parts of a textbook are organized by sequence. Sequence is the order in which a series of events occurs. Sometimes the text uses signal words, such as *after*, *next*, *then*, and *finally* to show sequence. Look for the signal words in the paragraph below.

The *Titanic* was the largest ship afloat. A few days into its first voyage, the *Titanic* struck an iceberg. The iceberg cut a long hole in the *Titanic's* hull. Soon after, the hull began to fill with water. Then, the ship's bow slipped under water and the *Titanic* broke in two. Finally, the *Titanic* sank to the bottom of the Atlantic Ocean.

A flowchart can help you understand the sequence. To make a flowchart, write each step in a box. Place the boxes in order.

#### The *Titanic*

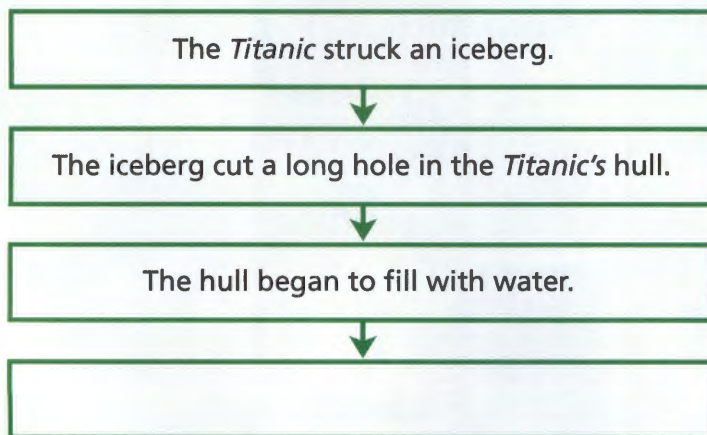

### Apply It!

In your notebook, copy the flowchart. Then add the next steps.

As you read Section 3, create a flowchart showing how pressure is transmitted in a fluid. As you read Section 4, create a flowchart on how an atomizer works.



## Staying Afloat

Why doesn't a heavy boat sink? In this investigation, you will design and build a boat that can float in water and carry cargo. You will find out what forces in fluids make an object sink or float.

### Your Goal

To construct a boat that can float in water and carry cargo

Your boat must

- be made of metal only
- support a cargo of 50 pennies without allowing any water to enter for at least 10 seconds
- travel at least 1.5 meters
- be built following the safety guidelines in Appendix A

### Plan It!

Before you design your boat, think about the shape of real ships. Preview the chapter to find out what makes an object float. Then look for simple metal objects that you can form into a boat. Compare different materials and designs to build the boat that best fits the goals listed above. After your teacher approves your design, build your boat and test it.





# Pressure

CALIFORNIA

## Standards Focus

**S 8.8.d** Students know how to predict whether an object will float or sink.

**S 8.9.f** Apply simple mathematical relationships to determine a missing quantity in a mathematic expression, given the two remaining terms (including  $\text{speed} = \text{distance}/\text{time}$ ,  $\text{density} = \text{mass}/\text{volume}$ ,  $\text{force} = \text{pressure} \times \text{area}$ ,  $\text{volume} = \text{area} \times \text{height}$ ).

Lab  
zone

## Standards Warm-Up

### Does Water Push Back?

1. Fill a large sink with water. Drop a deflated balloon into the water and note what happens.
2. Now fill the balloon with air and push the balloon into the water. Note what happens when you let go of the balloon.

#### Think It Over

**Drawing Conclusions** Compare your observations in Steps 1 and 2. Why did an air-filled balloon act differently from the deflated one?

 What does pressure depend on?

 How do fluids exert pressure?

 How does fluid pressure change with elevation and depth?

### Key Terms

- pressure
- pascal
- fluid
- barometer

Outside, deep snow covers the ground. You put on your sneakers and head out, shovel in hand. When you step outside, your foot sinks deep into the snow. It's nearly up to your knees! Nearby, a sparrow hops across the surface of the snow. Unlike you, the bird does not sink. In fact, it barely leaves a mark! Why do you sink into the snow while the sparrow rests on the surface? The answer has to do with pressure.

## What Is Pressure?

The word *pressure* is related to the word *press*. You may recall that Earth's gravity pulls you downward with a force equal to your weight. Due to gravity, your feet exert a force on the surface of Earth over an area the size of your feet. In other words, your feet exert pressure on the ground.

Exerting pressure  
on snow ▶





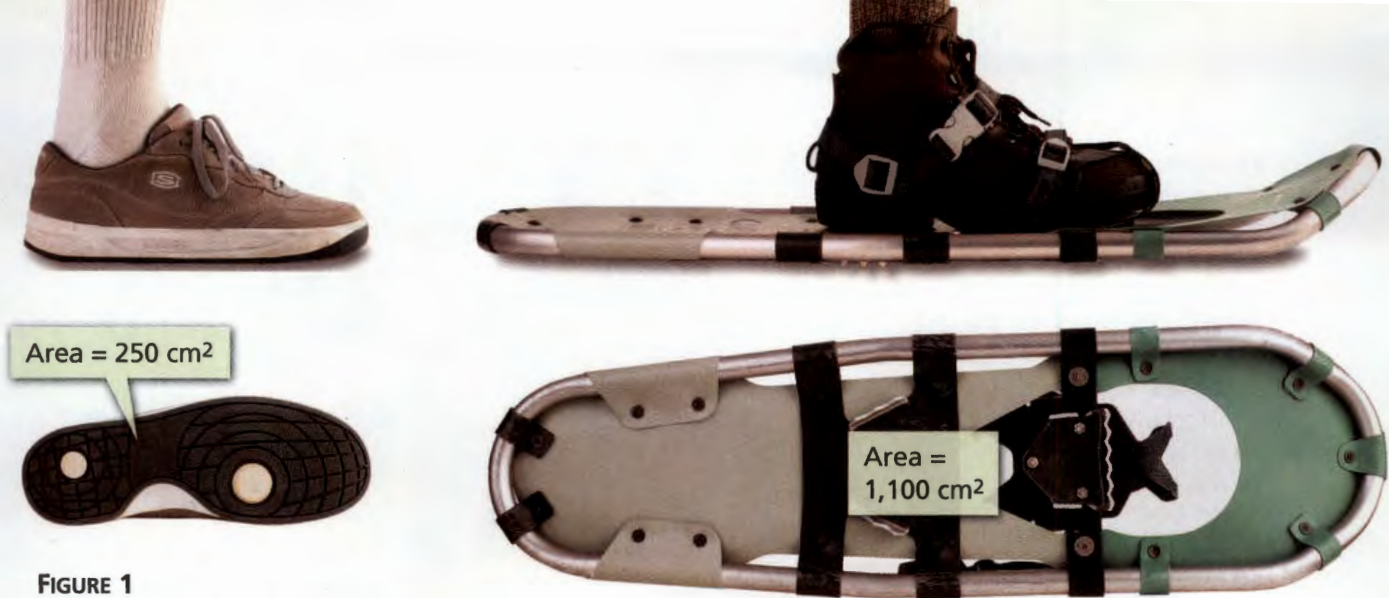

FIGURE 1

### Pressure and Area

The amount of pressure depends on the area over which a force is distributed. **Inferring** Which type of shoe would you use to keep from sinking into deep snow?

**Pressure and Area** 🚗 The amount of pressure you exert depends on the area over which you exert a force. The larger the area over which the force is distributed, the less pressure is exerted.

In order to stand on snow without sinking, you can change the area over which you exert the force of your weight. Figure 1 shows that if you wear sneakers, your weight is distributed over the soles of both shoes. You'll exert pressure over an area of only about  $250 \text{ cm}^2 \times 2$ , or  $500 \text{ cm}^2$ , and sink into the snow. But if you wear snowshoes, your weight is distributed over a much greater area—about  $1,100 \text{ cm}^2 \times 2$ , or  $2,200 \text{ cm}^2$ . Because your weight is distributed over a greater area, the pressure exerted on the snow is much less. Like a sparrow, you can stand on the snow without sinking!

**Calculating Pressure** **Pressure** is equal to the force exerted on a surface divided by the total area over which the force is exerted. You can calculate pressure using the formula below.

$$\text{Pressure} = \frac{\text{Force}}{\text{Area}}$$

Force is measured in newtons (N). Area is measured in square meters ( $\text{m}^2$ ). Since force is divided by area, the SI unit of pressure is the newton per square meter ( $\text{N}/\text{m}^2$ ). This unit of pressure is also called the **pascal** (Pa):  $1 \text{ N}/\text{m}^2 = 1 \text{ Pa}$ . It is named for the French mathematician Blaise Pascal.



**Reading Checkpoint**

What is the SI unit of pressure called?

### Math Skills

#### Area

The area of a surface is the number of square units that it covers. To find the area of a rectangle, multiply its length by its width. The area of the rectangle below is  $2 \text{ cm} \times 3 \text{ cm}$ , or  $6 \text{ cm}^2$ .

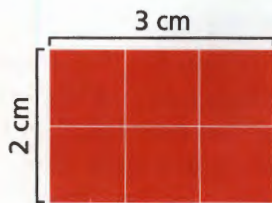

**Practice Problem** Which has a greater area: a rectangle that is  $4 \text{ cm} \times 20 \text{ cm}$ , or a square that is  $10 \text{ cm} \times 10 \text{ cm}$ ?



FIGURE 2

### Fluid Particles

The particles that make up a fluid move constantly in all directions. When a particle collides with a surface, it exerts a force on the surface.

#### Relating Cause and Effect

*What will happen to the force exerted by the particles in the chair when you add more air to the chair?*



## Fluid Pressure

Solids such as sneakers are not the only materials that exert pressure. Fluids also exert pressure. A **fluid** is a material that can easily flow. As a result, a fluid can change shape. Liquids such as water and oil and gases such as air and helium are examples of fluids. Understanding pressure in fluids will help you to predict whether an object will float or sink.

**What Causes Fluid Pressure?** Think about the tiny particles that make up a fluid. Particles in a fluid constantly move in all directions, as shown in Figure 2. As they move, the particles collide with each other and with any surface that they meet.

As each particle of a fluid collides with a surface, it exerts a force on the surface. 🇵🇸 **In a fluid, all of the forces exerted by the individual particles combine to make up the pressure exerted by the fluid.** Because the number of particles is large, you can consider the fluid as a whole. So, the pressure exerted by a fluid is the total force exerted by the fluid divided by the area over which the force is exerted.

**Air Pressure** Did you know that you live at the bottom of 100 kilometers of fluid? This fluid, called air, is the mixture of gases that makes up Earth's atmosphere. These gases press down on everything on Earth's surface, all the time. Air exerts pressure because it has mass. Each cubic meter of air around you has a mass of about 1 kilogram. Because the force of gravity pulls down on this mass of air, the air has weight. The weight of the air is the force that produces air pressure, or atmospheric pressure.

Lab  
zone

### Try This Activity

#### Card Trick

1. Fill a small plastic cup to the brim with water. Gently place an index card over the top of the cup.
2. Hold the card in place and slowly turn the cup upside down. Let go of the card. What happens? Without touching the card, turn the container on its side.

**Inferring** Why does the water stay in the cup when you turn the cup upside down?



**Balanced Pressure** Hold out your hand, palm up. You are holding up air. At sea level, atmospheric pressure is about 101,300 Pa. The surface area of your hand is about 100 cm<sup>2</sup>. So, the weight supported by the surface area of your hand is about 1,000 newtons, or about the same weight as that of a large washing machine!

How could your hand possibly support that weight and not feel it? In a stationary fluid, pressure at a given point is exerted equally in all directions. The weight of the atmosphere does not just press down on your hand. It presses on your hand from every direction. The pressures balance each other.

Balanced pressures also explain why the tremendous air pressure pushing on you from all sides does not crush you. Your body contains fluids that exert outward pressure. For example, your lungs and sinus cavities contain air. Your cells and blood vessels contain liquids. Pressure from fluids inside your body balances the air pressure outside your body.

What happens when air pressure becomes unbalanced? Look at Figure 4. When the can is full of air, the air pressure inside the can balances the atmospheric pressure outside the can. When air is removed from the can, the unbalanced force of the outside air pressure crushes the can.

**FIGURE 3**  
**Atmospheric Pressure**  
The pressure of Earth's atmosphere is exerted over the entire surface of your hand. The downward pressure is the same as the upward pressure.

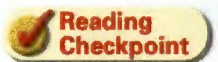
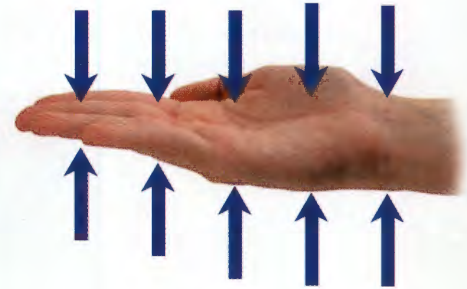

**How is the pressure on your hand balanced?**

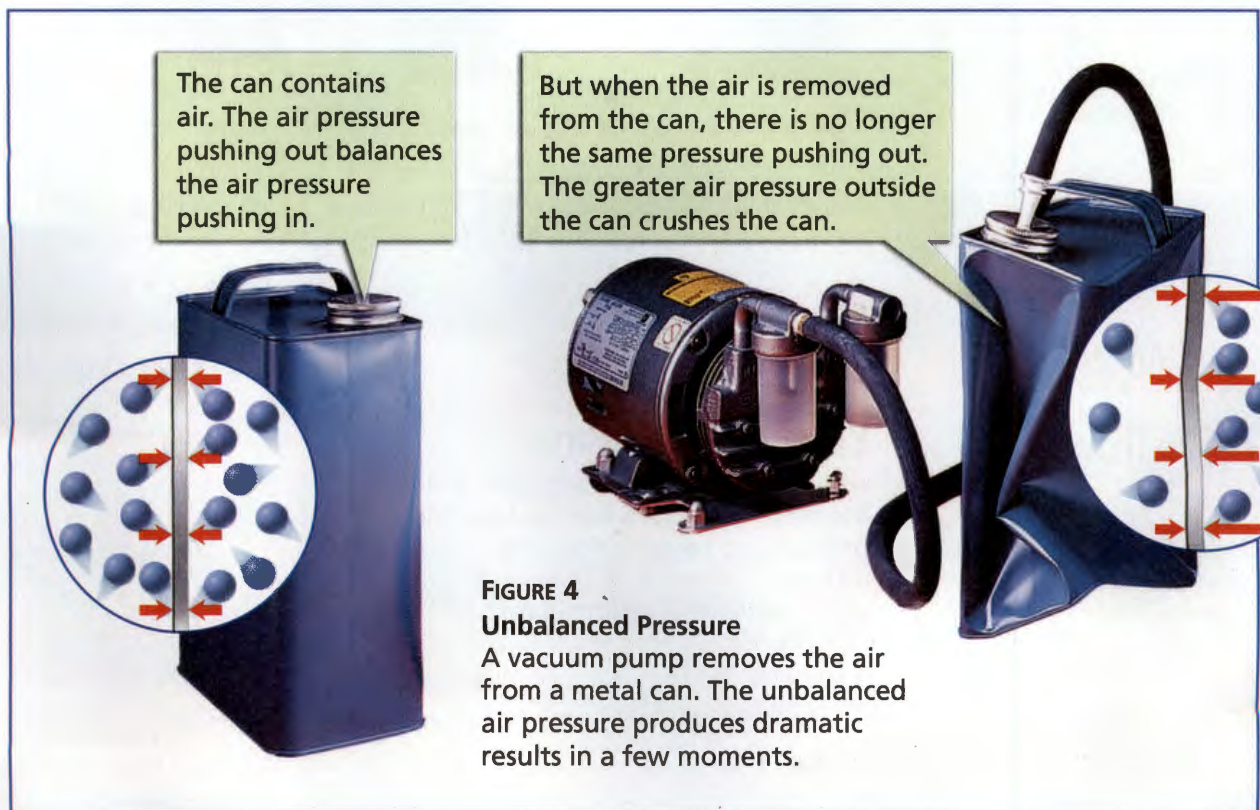



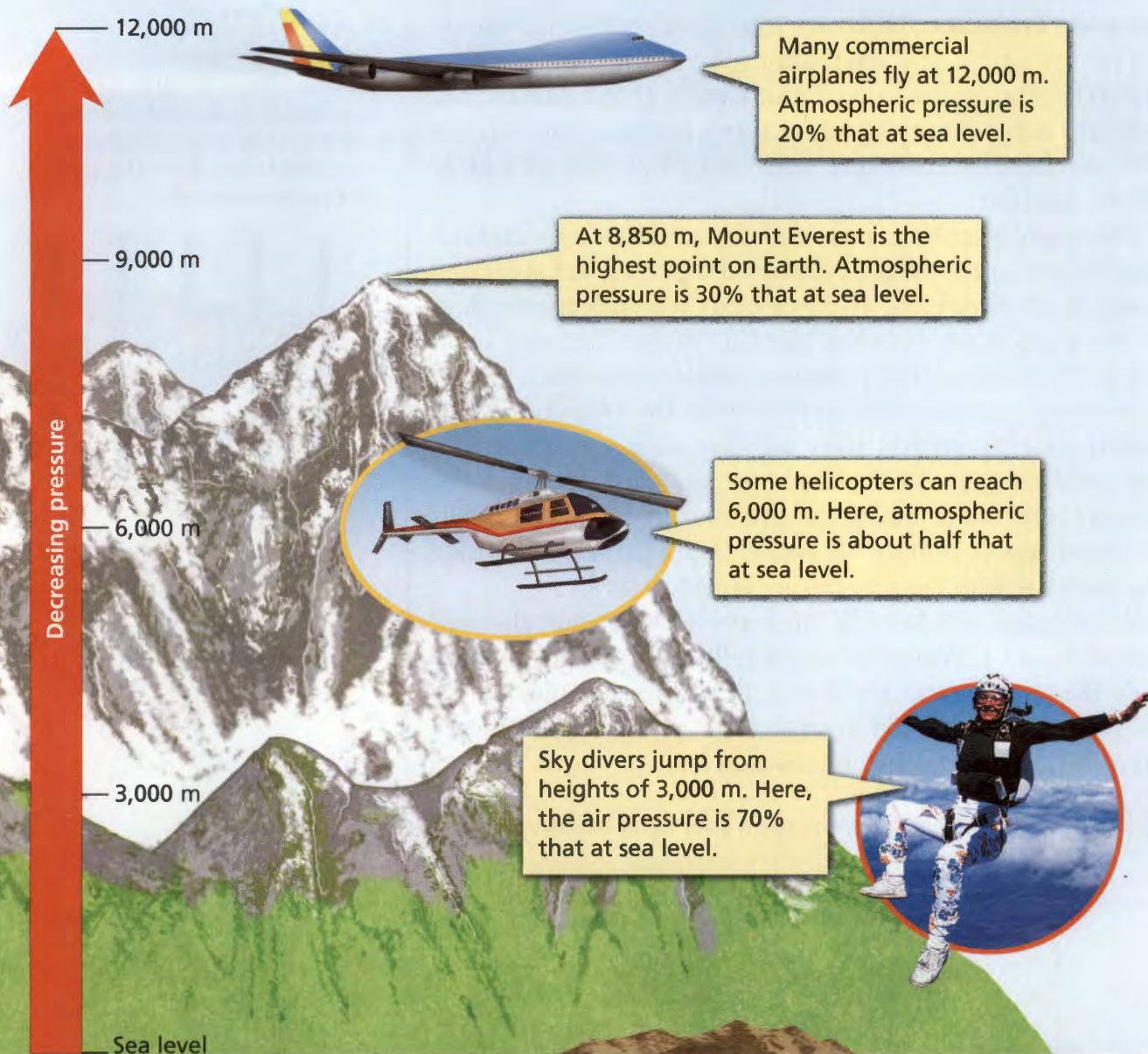

FIGURE 5  
**Pressure Variations**

Atmospheric pressure decreases gradually as the elevation above sea level increases. Water pressure increases rapidly as the water depth increases. **Applying Concepts** Why do airplanes have pressurized cabins?

**Go Online**  
 SCILINKS™  
 NSTA

For: Links on fluids and pressure  
 Visit: [www.SciLinks.org](http://www.SciLinks.org)  
 Web Code: scn-1331



## Variations in Fluid Pressure

Have you ever felt your ears “pop” as you rode up in an elevator? What happens to pressure as you climb to a higher elevation or sink to a lower depth within a fluid? Figure 5 shows how pressure changes depending on where you are.

**Atmospheric Pressure and Elevation** The “popping” in your ears is caused by changing air pressure. At higher elevations, there is less air above you and therefore less air pressure. ➡ **Atmospheric pressure decreases as your elevation increases.**

When the air pressure outside your body decreases, the air pressure inside also decreases, but more slowly. So, for a moment, the air pressure behind your eardrums is greater than it is in the air outside. Your body releases this pressure with a “pop,” balancing the pressures.

**Water Pressure and Depth** You experience a different type of pressure change if you dive underwater. ➡ **Water pressure increases as depth increases.** So if you dive into a body of water, pressure becomes greater as you descend. The deeper you swim, the greater the pressure you feel.



At sea level, standard atmospheric pressure is about  $100,000 \text{ N/m}^2$ .

Just 10 m below the surface, the water pressure on a scuba diver is double the atmospheric pressure at sea level.



The gulper eel can live 2,500 m below the surface. Pressure here is about 250 times greater than standard atmospheric pressure.

Piloted submersibles can explore as deep as 6,500 m. Here, water pressure is 650 times greater than at sea level.



Sea level

3,000 m

6,000 m

Increasing pressure



FIGURE 6

### Aneroid Barometer

An aneroid barometer measures atmospheric pressure.

**Interpreting Photographs** What type of weather might be coming when atmospheric pressure decreases?



Water pressure is a result of the weight of the water above a particular point. At greater depths, there is more water above that point and therefore more weight to support. In addition, air in the atmosphere pushes down on the water. Therefore, the total pressure at a given point beneath the water results from the weight of the water plus the weight of the air above it. In the deepest parts of the ocean, the pressure is more than 1,000 times the air pressure you experience every day.

**Measuring Pressure** You can measure atmospheric pressure with an instrument called a **barometer**. Weather forecasters use the pressure reading from a barometer to help forecast the weather. Rapidly decreasing atmospheric pressure usually means a storm is on its way. Increasing pressure is often a sign of fair weather.

The barometer you usually see hanging on a wall is an aneroid barometer. Forecasters will often express the pressure in units of millimeters of mercury or inches of mercury. Those units are based on the original type of barometer, which measured how far the atmosphere pushed liquid mercury up a tube. Standard atmospheric pressure at sea level may be reported as 760 millimeters of mercury, which is about the same as 101,300 Pa.



**Reading Checkpoint**

What instrument measures atmospheric pressure?

## Section 1 Assessment

S 8.8.d, S 8.9.f  
E-LA: Reading 8.1.0

### Vocabulary Skill Identify Multiple Meanings

Use the scientific meanings for *fluid* and *pressure* to help you define the term *fluid pressure*.



### Reviewing Key Concepts

- a. Reviewing** What two factors does pressure depend on?

**b. Comparing and Contrasting** Who exerts more pressure on the ground—a 500-N woman standing in high heels with a total area of  $0.005 \text{ m}^2$ , or the same woman standing in work boots with a total area of  $0.05 \text{ m}^2$ ? Calculate the pressure she exerts on the ground in both cases.
- a. Summarizing** How do fluids exert pressure?

**b. Explaining** Why aren't you crushed by the weight of the atmosphere?

**c. Inferring** How is your body similar to the can containing air shown in Figure 4?

- a. Describing** How does atmospheric pressure change as you move up away from sea level?

**b. Comparing and Contrasting** Compare the change in atmospheric pressure with elevation to the change in water pressure with depth.

**c. Applying Concepts** Why must an astronaut wear a pressurized suit in space?

Lab  
zone

### At-Home Activity

**Water and Weight** Fill a pot with water from the sink. Fill a sandwich bag with water at the same temperature. Seal the bag and drop it into the pot. Note what happens. Then repeat the experiment with a sandwich bag filled with hot water and a sandwich bag filled with water that is just slightly above the freezing point. Describe your observations.



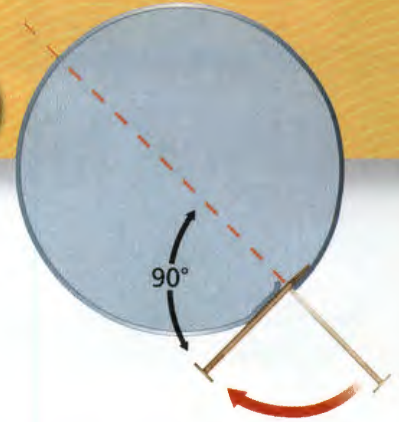

## Spinning Sprinklers

S 8.2.e, 8.9.c

### Problem

What factors affect the speed of rotation of a lawn sprinkler?

### Skills Focus

designing experiments, controlling variables

### Materials

- empty soda can
- fishing line, 30 cm
- waterproof marker
- wide-mouth jar or beaker
- stopwatch
- nails of various sizes
- large basin

### Procedure



#### PART 1 Making a Sprinkler

1. Fill the jar with enough water to completely cover a soda can. Place the jar in the basin.
2. Bend up the tab of a can and tie the end of a length of fishing line to it. **CAUTION:** *The edge of the can opening can be sharp.*
3. Place a mark on the can to help you keep track of how many times the can spins.
4. Using the small nail, make a hole in the side of the can about 1 cm up from the bottom. Poke the nail straight in. Then twist the nail until it makes a right angle with the radius of the can as shown in the figure above. **CAUTION:** *Nails are sharp and should be used only to puncture the cans.*
5. Submerge the can in the jar and fill the can to the top with water.
6. Quickly lift the can with the fishing line so that it is 1–2 cm above the water level in the jar. Practice counting how many spins the can completes in 15 seconds.

#### PART 2 What Factors Affect Spin?

7. How does the size of the hole affect the number of spins made by the can? Propose a hypothesis and then design an experiment to test the hypothesis. Obtain your teacher's approval before carrying out your experiment. Record all your data.
8. How does the number of holes affect the number of spins made by the can? Propose a hypothesis and then design an experiment to test the hypothesis. Obtain your teacher's approval before carrying out your experiment. Record all your data.

### Analyze and Conclude

1. **Designing Experiments** How does the size of the hole affect the rate of spin of the can? How does the number of holes affect the rate of spin of the can?
2. **Controlling Variables** What controlled parameters did you leave unchanged in this experiment? What other parameters might affect the number of spins made by the can?
3. **Interpreting Data** Explain the motion of the can in terms of unbalanced forces.
4. **Classifying** Which of Newton's three laws of motion could you use to explain the motion of the can? Explain.
5. **Communicating** Use the results of your experiment to write a paragraph that explains why a spinning lawn sprinkler spins.

### More to Explore

Some sprinkler systems use water pressure to spin. Examine one of these sprinklers to see the size, direction of spin, and number of holes. What would happen if you connected a second sprinkler to the first with another length of hose? If possible, try it.



# Floating and Sinking

## CALIFORNIA

## Standards Focus

**S 8.8.c** Students know the buoyant force on an object in a fluid is an upward force equal to the weight of the fluid the object has displaced.

**S 8.8.d** Students know how to predict whether an object will float or sink.

How can you predict whether an object will float or sink in a fluid?

What is the effect of the buoyant force?

## Key Terms

- density
- buoyant force
- Archimedes' principle

## Lab zone

## Standards Warm-Up

## What Can You Measure With a Pencil?



1. Carefully stick a metal thumbtack in the eraser of an unsharpened wooden pencil. You have built a device called a hydrometer.
2. Place the pencil in a glass of water with the eraser and tack pointing down. Note how far the pencil sinks in the water by marking the edge of the pencil at the water's surface line with a waterproof marker.
3. Remove the pencil from the water. Measure the length the pencil sunk in centimeters.
4. Dissolve 10 spoonfuls of sugar into the glass of water. Try out your hydrometer in this liquid. Again mark how far the pencil sinks. Then remove the pencil from the water and once again measure the length the pencil sunk in centimeters.



## Think It Over

**Predicting** Compare your observations in Steps 3 and 4. Predict what will happen if you use 20 spoonfuls of sugar in a glass of water. Test your prediction.

In April 1912, the *Titanic* departed from England on its first and only voyage. At the time, it was the largest ship afloat—nearly three football fields long. The *Titanic* was also the most technologically advanced ship in existence. Its hull was divided into compartments, and it was considered to be unsinkable.

Yet a few days into the voyage, the *Titanic* struck an iceberg.

One compartment after another filled with water. Less

than three hours later, the bow of the great ship slipped under the waves. As the stern rose

high into the air, the ship broke in two.

Both pieces sank to the bottom of the Atlantic Ocean. More than a thousand people died.

◀ The bow section of the *Titanic* resting on the ocean floor





## Density

The Titanic sank because of a change in its density. Recall that the **density** of a substance is its mass per unit volume.

$$\text{Density} = \frac{\text{Mass}}{\text{Volume}}$$

For example, one cubic centimeter ( $\text{cm}^3$ ) of copper has a mass of 8.8 grams, so its density is  $8.8 \text{ g/cm}^3$ . One cubic centimeter of plastic has a mass of only about 0.93 gram. So the density of plastic is about  $0.93 \text{ g/cm}^3$ . Copper is more dense than plastic. The density of water is  $1.0 \text{ g/cm}^3$ . So water is less dense than copper but more dense than plastic.

**Comparing Densities of Substances** Figure 7 shows several substances and their densities. Each substance has its own density. Some liquids float on top of other liquids. The substances with the greatest densities are near the bottom.

 **By comparing densities, you can predict whether an object will float or sink in a fluid.** An object that is more dense than the fluid it is in sinks. An object that is less dense than the fluid floats on the surface. An object with a density equal to that of the fluid floats at a constant depth.



**Reading Checkpoint**

When will an object float on a fluid's surface?

Substance	Density ( $\text{g/cm}^3$ )
Wood	0.7
Corn oil	0.925
Plastic	0.93
Water	1.00
Tar ball	1.02
Glycerin	1.26
Rubber washer	1.34
Corn syrup	1.38
Copper wire	8.8
Mercury	13.6

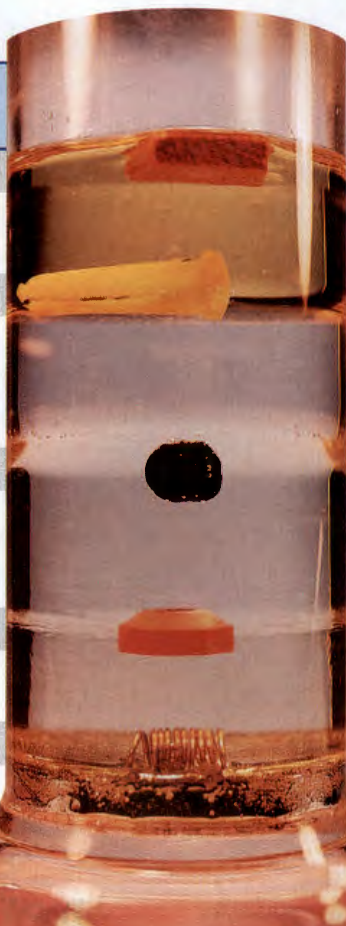

## Math Skills

### Calculating Density

The density of a substance is its mass per unit of volume.

$$\text{Density} = \frac{\text{Mass}}{\text{Volume}}$$

For example, a sample of liquid has a mass of 24 g and a volume of 16 mL. What is its density?

$$\begin{aligned} \text{Density} &= \frac{24 \text{ g}}{16 \text{ mL}} \\ &= 1.5 \text{ g/mL} \end{aligned}$$

**Practice Problem** A piece of metal has a mass of 43.5 g and a volume of  $15 \text{ cm}^3$ . What is its density?

FIGURE 7

### Densities of Substances

You can use density to predict whether an object will sink or float when placed in a liquid.

**Predicting** Will a rubber washer sink or float in corn oil?



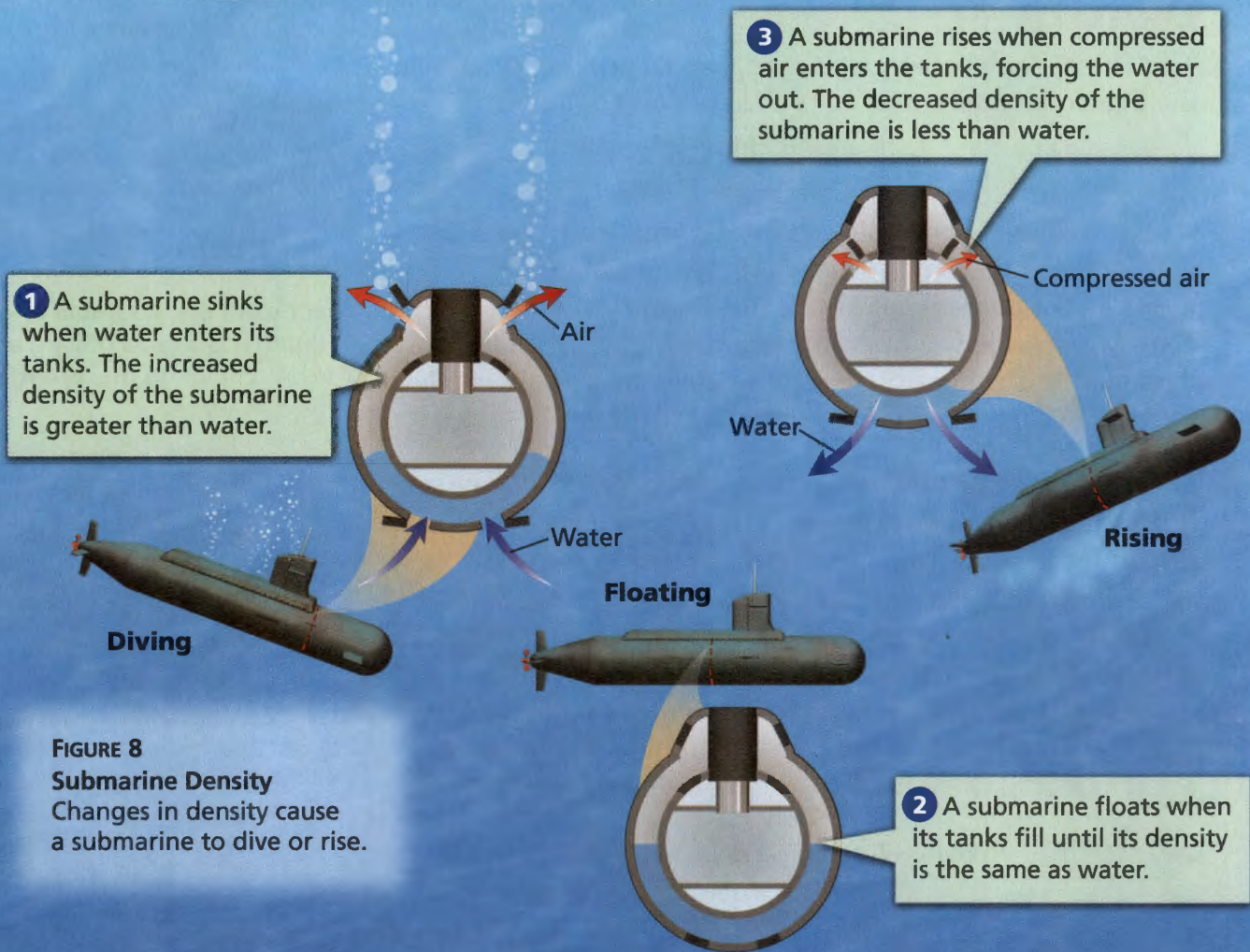

**FIGURE 8**  
**Submarine Density**  
 Changes in density cause a submarine to dive or rise.

**Changing Density** Changing density can explain why an object floats or sinks. For example, you can change the density of water by freezing it into ice. Since water expands when it freezes, the ice occupies more space than the water. That's why ice is less dense than water. But it's just a bit less dense! So most of an ice cube floating on the surface is below the water's surface.

You can make an object sink or float in a fluid by changing its density. Look at Figure 8 to see how this happens to a submarine. The density of a submarine increases when water fills its flotation tanks. This happens because the overall mass of the submarine increases, but its volume remains the same. So the submarine will sink. To make the submarine rise in the water, the engineer pumps water out of the flotation tanks, decreasing the submarine's mass. Its density decreases, and it rises.



**Reading Checkpoint**

When will a submarine rise?



## Buoyancy

Ships are designed to have buoyancy—the ability to float. How is it possible that a huge ship can float easily on the surface of water under certain conditions, and then in a few hours become a sunken wreck? To answer this question, you need to understand the buoyant force.

**Gravity and the Buoyant Force** If you have ever picked up an object under water, you know that it seems much lighter in water than in air. Water and other fluids exert an upward force called the **buoyant force** that acts on a submerged object.

➡ **The buoyant force acts in the direction opposite to the force of gravity, so it makes an object feel lighter.** The less dense the object is, the greater the buoyant force it experiences.

As you can see in Figure 9, a fluid exerts pressure on all surfaces of a submerged object. Since the pressure in a fluid increases with depth, the upward pressure on the bottom of the object is greater than the downward pressure on the top. The result is a net force acting upward on the submerged object. This is the buoyant force.

Remember that the weight of a submerged object is a downward force. If an object's weight is greater than the buoyant force, a net force acts downward on the object. The object will sink. If the weight of an object is equal to the buoyant force, no net force acts on the object. The object will not sink. A submerged object whose weight is equal to the buoyant force also has no net force acting on it. The object will not sink.

Remember that you can also use density to explain why objects float or sink. In Figure 10, the density of the jellyfish is less than that of water, while the turtle's density is equal to that of water. The jellyfish and the turtle float. The density of the lobster is greater than water. The lobster sinks.

FIGURE 9

### Buoyant Force

The pressure on the bottom of a submerged object is greater than the pressure on the top. The result is a net force in the upward direction.

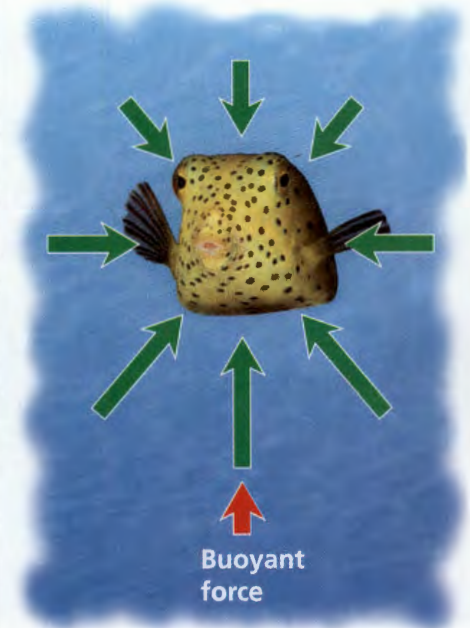
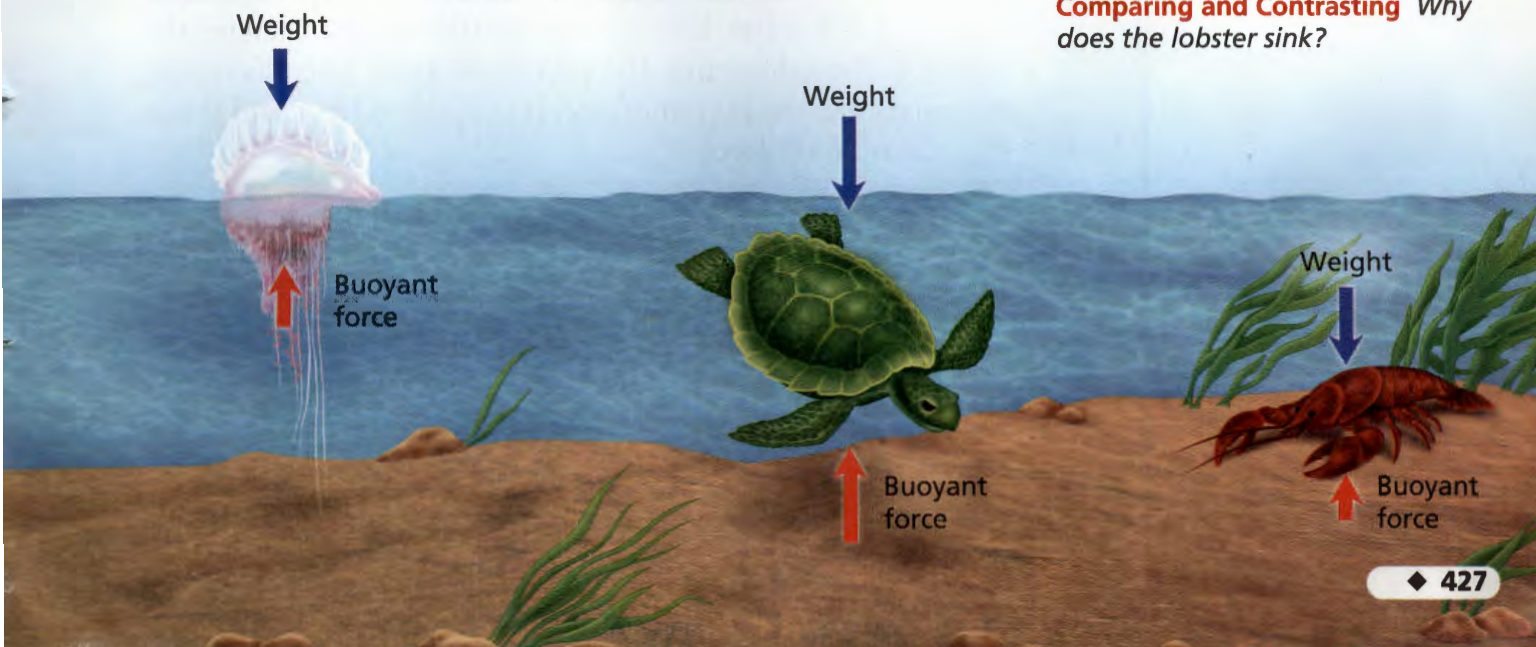

FIGURE 10

### Buoyant Force and Weight

The buoyant force works opposite the weight of an object. The forces acting on the jellyfish and turtle are balanced, so they float in place. The forces on the lobster are unbalanced.

**Comparing and Contrasting** Why does the lobster sink?





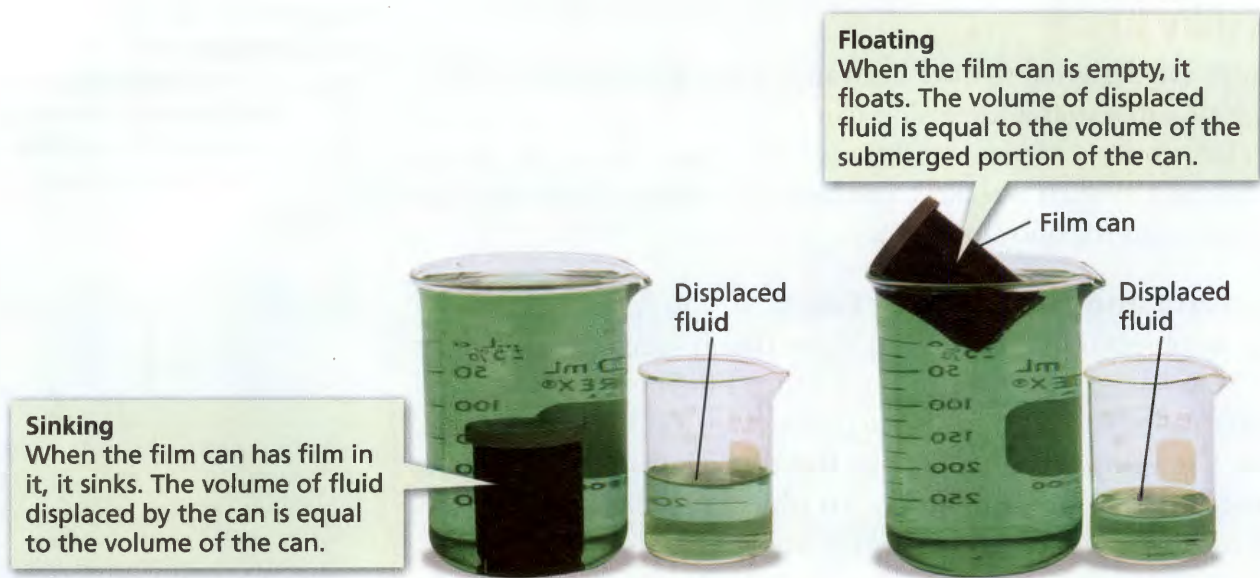

FIGURE 11

### Archimedes' Principle

Archimedes' principle applies to sinking and floating objects.

**Predicting** *If you press down on the floating film can, what will happen to the volume of the displaced fluid in the small beaker?*

## Archimedes' Principle

All objects take up space. A submerged object displaces, or takes the place of, a volume of fluid equal to its own volume. A partly submerged object displaces a volume of fluid equal to the volume of its submerged portion only. You can see this in Figure 11.

Archimedes, a mathematician of ancient Greece, discovered a connection between the weight of a fluid displaced by an object and the buoyant force acting on it. **Archimedes' principle** states that the buoyant force acting on a submerged object is equal to the weight of the volume of fluid displaced by the object. Suppose your body displaces 50 liters of water in a swimming pool. The buoyant force on you will be equal to the weight of 50 liters of water, or about 500 N.

**Submarines** How can a submarine dive and float? Since the buoyant force is equal to the weight of the displaced fluid, the buoyant force on the submerged submarine stays the same. Changing the water level in the flotation tanks changes the weight of the submarine. The submarine sinks when its weight is greater than the buoyant force. It rises when its weight is less than the buoyant force.

**Balloons** Air is a fluid. A balloon filled with air is denser than the surrounding air because the air inside it is under pressure. The denser air inside makes it fall to the ground. But if the air inside the balloon is heated, it becomes less dense, and the balloon rises. You can also fill a balloon with helium. A helium balloon rises because helium is less dense than air.

**Video Field Trip**  
Discovery Channel School  
*Forces in Fluids*



**Reading Checkpoint**

Why does a helium balloon float in air?



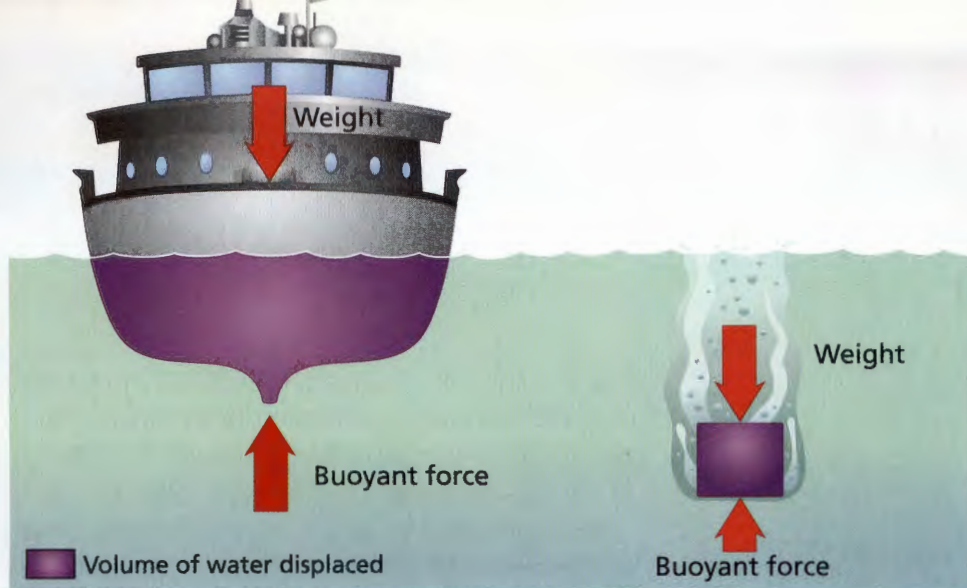

**FIGURE 12**  
**Floating Ship**  
A solid block of steel sinks in water. A steel ship with the same weight floats on the surface.

**Ships** You can use Archimedes' principle to explain why a ship floats on the surface. Since the buoyant force equals the weight of the displaced fluid, the buoyant force will increase if more fluid is displaced. A large object displaces more fluid than a small object. A greater buoyant force acts on the larger object even if the large object has the same weight as the small object.

Look at Figure 12. The ship's hull has the same mass as the solid block of steel, but its shape causes the ship to displace a greater volume of water. According to Archimedes' principle, the buoyant force is equal to the weight of the displaced water. Since a ship displaces more water than a block of steel, a greater buoyant force acts on the ship. The buoyant force acting on it is equal to its weight, and the ship floats on the surface.

## Section 2 Assessment

S 8.8.c, 8.8.d E-LA: Reading 8.1.0

### Vocabulary Skill Identify Multiple Meanings

Use the scientific meaning of *force* to define the key term *buoyant force*.

- c. **Calculating** An object that weighs 340 N floats on a lake. What is the weight of the displaced water? What is the buoyant force?

### Reviewing Key Concepts

- Defining** What is density?
  - Explaining** How can you use the density of an object to predict whether it will float or sink in water?
  - Applying Concepts** Some canoes have compartments on either end that are hollow and watertight. These canoes won't sink, even when they capsize. Explain why.
- Explaining** How does the buoyant force affect a submerged object?
  - Summarizing** How does Archimedes' principle relate the buoyant force acting on an object to the fluid displaced by the object?

Lab  
zone

### At-Home Activity

**Changing Balloon Density** Attach paper clips to the string of a helium balloon. Ask a family member to predict how many paper clips you will need to attach to make the balloon sink to the floor. How many paper clips can you attach and still keep the helium balloon suspended in the air? Explain how adding paper clips changes the overall density of the balloon.



# Sink and Spill

 S 8.8.c, 8.9.a

## Problem

How is the buoyant force acting on an object in a fluid related to the weight of the fluid the object displaces?

## Skills Focus

controlling variables, interpreting data, drawing conclusions

## Materials

- paper towels • pie pan
- triple-beam balance • beaker, 600-mL
- jar with watertight lid, about 30-mL
- table salt

## Procedure



1. Preview the procedure and copy the data table into your notebook. Predict the relationship you will find between the buoyant force and the weight of the displaced water.
2. Find the mass, in kilograms, of a dry paper towel and the pie pan together. To convert grams to kilograms, divide the mass in grams by 1,000. Multiply the mass by  $9.8 \text{ m/s}^2$ . This gives you the weight in newtons. Record it in your data table.
3. Place the 600-mL beaker, with the dry paper towel under it, in the middle of the pie pan. Fill the beaker to the very top with water.
4. Fill the jar about halfway with salt. (The jar and salt must be able to float in water.) Find the mass of the salt and the dry jar (with its cover on) in kilograms. Multiply the mass by  $9.8 \text{ m/s}^2$ . Record this weight in your data table.
5. Gently lower the jar into the 600-mL beaker. (If the jar sinks, take it out and remove some salt. Repeat Steps 2, 3, and 4.) Estimate the fraction of the jar that is underwater, and record it.
6. Once all of the displaced water has been spilled, find the total mass of the paper towel and pie pan containing the water in kilograms. Multiply the mass by  $9.8 \text{ m/s}^2$  and record the result in your data table.
7. Empty the pie pan. Dry off the pan and jar.
8. Repeat Steps 3 through 7 several more times. Each time fill the jar with a different amount of salt, but make sure the jar still floats.
9. Record the buoyant force for each trial in your data table. (*Hint:* When an object floats, the buoyant force is equal to the weight of the object.)
10. Calculate the weight of the displaced water in each case. Record it in your data table.

Data Table

Jar	Weight of Empty Pie Pan and Dry Paper Towel (N)	Weight of Jar, Salt, and Cover (N)	Weight of Pie Pan With Displaced Water and Paper Towel (N)	Fraction of Jar Submerged in Water	Buoyant Force (N)	Weight of Displaced Water (N)
1						
2						
3						



## Analyze and Conclude

1. **Controlling Variables** In each trial, the jar had a different weight. How did this affect the way that the jar floated?
2. **Interpreting Data** The jar had the same volume in every trial. Why did the volume of displaced water vary?
3. **Drawing Conclusions** What can you conclude about the relationship between the buoyant force acting on an object and the weight of the water it displaces?

4. **Drawing Conclusions** If you put too much salt in the jar, it will sink. What can you conclude about the buoyant force in this case? How can you determine the buoyant force for an object that sinks?
5. **Communicating** Write a paragraph suggesting changes to the experiment that would improve the accuracy of your results.

## Design an Experiment

How do you think your results would change if you used a liquid that is more dense or less dense than water? Design an experiment to test your hypothesis. What liquids will you use? Will you need equipment other than what you used for this experiment? If so, what will you need? *Obtain your teacher's permission before carrying out your investigation.*







# Pascal's Principle

**CALIFORNIA**
**Standards Focus**

**S 8.8.c** Students know the buoyant force on an object in a fluid is an upward force equal to the weight of the fluid the object has displaced.

-  What does Pascal's principle say about change in fluid pressure?
-  How does a hydraulic system work?

**Key Terms**

- Pascal's principle
- hydraulic system

**Lab zone**
**Standards Warm-Up**
**Why Does the Cartesian Diver Sink?**

1. Fill a plastic jar or bottle almost completely with water.
2. Make a Cartesian diver by bending a plastic straw into a U shape. Cut the ends so that each side is 4 cm long. Attach the ends with a paper clip. Drop the straw in the jar, paper clip first.
3. Attach more paper clips to the first one until the straw floats with its top about 0.5 cm above the surface. This is the diver.
4. Put the lid on the jar. Observe what happens when you slowly squeeze and release the jar several times.

**Think It Over**

**Observing** Describe the behavior of the Cartesian diver.

At first, you hesitate, but then you hold out your hand. The aquarium attendant places the sea star in your palm. You can feel motion on your skin. The many tiny “feet” on the animal’s underside look something like suction cups, and they tickle just a bit! The attendant explains that the sea star has a system of tubes containing water in its body. As the water moves around in the tubes, it creates changes in fluid pressure that allows the sea star to move.

A sea star uses fluid pressure to move. ►







**FIGURE 13**  
**Fluid Pressure**

A liquid that fills a bottle exerts pressure in all directions. If you squeeze the bottle, you increase the pressure. **Predicting** Suppose you opened the top of the water bottle. What would happen when you squeezed the bottle? Why?

## Transmitting Pressure in a Fluid

If you did the Standards Warm-Up, you may be wondering why the buoyancy of the Cartesian diver changes. Squeezing the bottle made the diver sink because you increased the pressure on the water inside the bottle. The water pushed into the straw, reducing the size of the pocket of air and increasing the diver's density. This happened no matter where you squeezed the bottle. By changing the fluid pressure at any spot in the closed container, you transmitted pressure throughout the container.

**Pascal's Principle** In the 1600s, Blaise Pascal developed a principle to explain how pressure is transmitted in a fluid. As you know, fluid exerts pressure on any surface it touches. For example, the colored water in each bottle shown in Figure 13 exerts pressure on the entire surface of the bottle—up, down, and sideways.

What happens if you squeeze the bottle when its top is closed? The water has nowhere to go, so it presses harder on the inside surface of the bottle. The water pressure increases everywhere in the bottle. This is shown by the increased length of the arrows on the right in Figure 13.

**Pascal's principle** states that pressure increases by the same amount throughout an enclosed or confined fluid. 🏠 **When force is applied to a confined fluid, the change in pressure is transmitted equally to all parts of the fluid.**



**Reading  
Checkpoint**

What is Pascal's principle?



System A

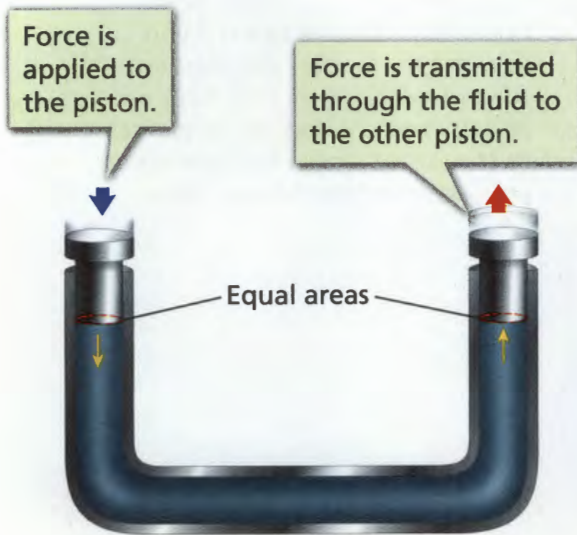

$$\frac{\text{Force}}{\text{Area}} = \text{Pressure} = \frac{\text{Force}}{\text{Area}}$$

System B

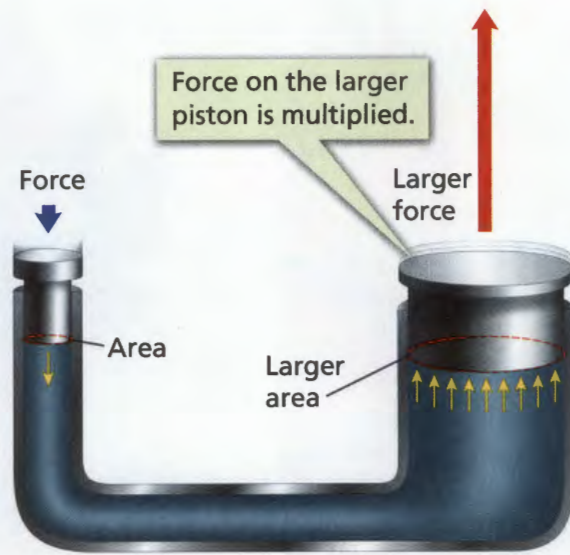

$$\frac{\text{Force}}{\text{Area}} = \text{Pressure} = \frac{\text{Larger force}}{\text{Larger area}}$$

**FIGURE 14**  
**Hydraulic Devices**

In a hydraulic device, a force applied to one piston increases the fluid pressure equally throughout the fluid. By changing the area of the pistons, the force can be multiplied.

**Problem Solving** To multiply the force applied to the left piston four times, how much larger must the area of the right piston be compared to the left piston?

**Pascal's Principle at Work** You can see Pascal's principle at work in Figure 14. A hydraulic device consists of two pistons, one at each end of a U-shaped tube. A piston is like a stopper that slides up and down in a tube.

Suppose you fill System A with water and then push down on the left piston. The increase in fluid pressure will be transmitted to the right piston. According to Pascal's principle, both pistons experience the same fluid pressure. Because both pistons have the same surface area, they will experience the same force.

Now look at System B. The right piston has a greater surface area than the left piston. Suppose the area of the small piston is 1 square centimeter and the area of the large piston is 9 square centimeters. The right piston has an area nine times greater than the area of the left piston. If you push down on the left piston, pressure is transmitted equally to the right piston. The force you exert on the left piston is multiplied nine times when it reaches the right piston. By changing the area of the pistons, you can multiply force by almost any amount you wish.

Go  online  
**active art**

For: Hydraulic Systems activity  
Visit: PHSchool.com  
Web Code: cgp-3033



**Reading  
Checkpoint**

How is force multiplied in System B?



# Hydraulic Systems

Have you ever wondered how a person can stop a large car by pressing down on a little pedal? Or how mechanics are able to raise cars off the ground so they can repair them? In both cases, hydraulic systems using Pascal's principle are at work. A **hydraulic system** uses liquids to transmit pressure and multiply force in a confined fluid. 🚗 A hydraulic system multiplies force by applying the force to a small surface area. The increase in pressure is then transmitted to another part of the confined fluid, which pushes on a larger surface area. Because they use fluids to transmit pressure, hydraulic systems have few moving parts that can jam, break, or wear down.

**Hydraulic Lifts** Hydraulic lift systems are used to raise cars off the ground so mechanics can repair them with ease. They are also used to lift the heavy ladder on a fire truck to reach the upper windows of a burning building. In addition, hydraulic lifts are used to operate many pieces of heavy construction equipment such as dump trucks, backhoes, snowplows, and cranes. Next time you see a construction vehicle at work, see if you can spot the hydraulic pistons in action.

## Reviewing Math: Algebra and Functions 7.3.3

### Math

### Analyzing Data

#### Comparing Hydraulic Lifts

The graph shows the relationship between the applied force and the lifting force for two hydraulic lifts.

- Reading Graphs** Suppose a force of 1,000 N is applied to both lifts. Use the graph to determine the lifting force of each lift.
- Reading Graphs** For Lift A, how much force must be applied to lift a 12,000-N object?
- Interpreting Data** By how much is the applied force multiplied for Lift A? Lift B?
- Interpreting Data** What does the slope of each line represent?
- Drawing Conclusions** Which lift would you choose if you wanted to lift a weight of 4,000 N? Explain.

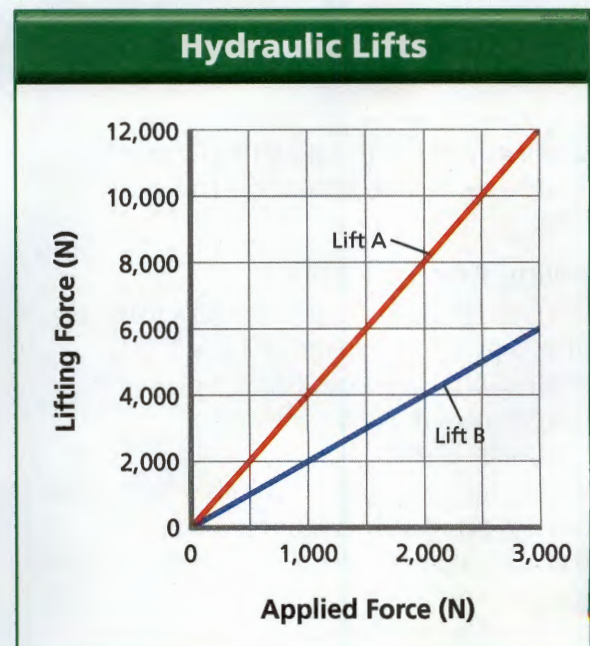



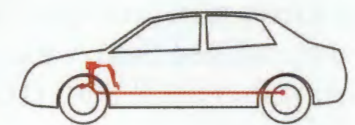
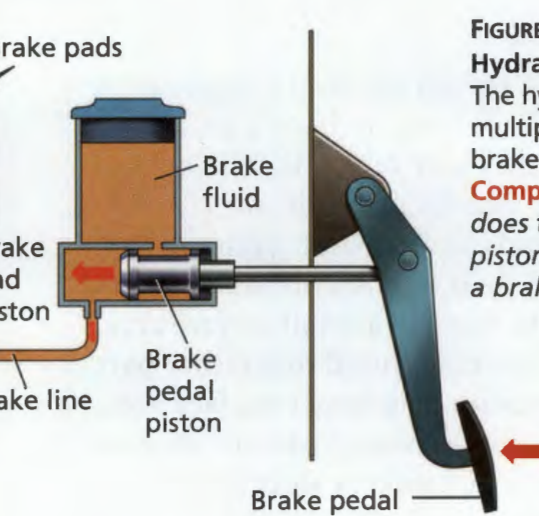
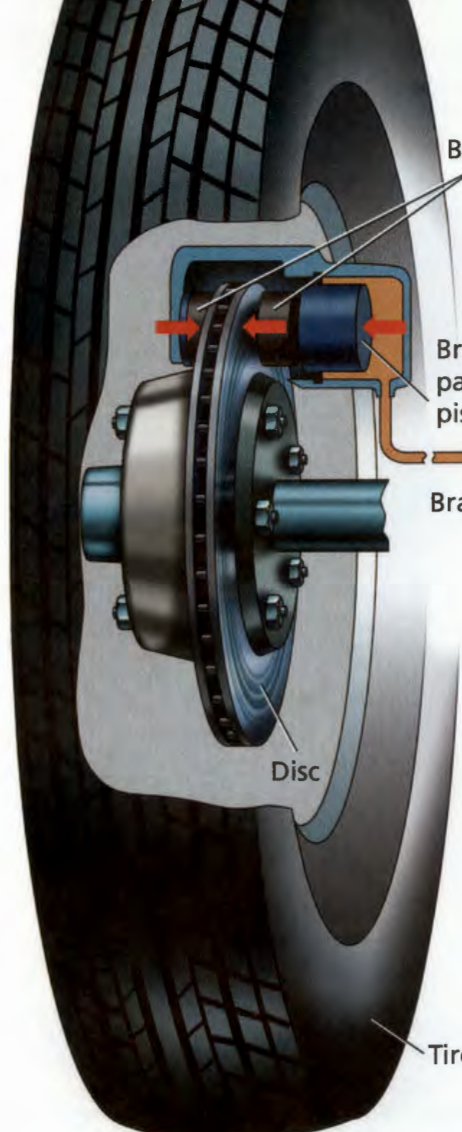

**FIGURE 15**  
**Hydraulic Brakes**  
 The hydraulic brake system of a car multiplies the force exerted on the brake pedal.  
**Comparing and Contrasting** How does the size of the brake pedal piston compare with the size of a brake pad piston?

**Hydraulic Brakes** You rely on Pascal's principle when you ride in a car. The brake system of a car is a hydraulic system. Figure 15 shows a simplified brake system with disc brakes. When a driver pushes down on the brake pedal, he or she pushes a small piston. The piston exerts pressure on the brake fluid. The increased pressure is transmitted through the fluid in the brake lines to larger pistons within the wheels of the car. Each of these pistons pushes on a brake pad. The brake pads rub against the brake disc, and the wheel's motion is slowed down by the force of friction. Because the brake system multiplies force, a person can stop a large car with only a light push on the brake pedal.

**Section 3 Assessment** S 8.8.c, E-LA: Reading 8.2.0

- Target Reading Skill Sequence** Create a flowchart to show how pressure is transmitted in a fluid.
- Reviewing Key Concepts**
  1. a. **Reviewing** According to Pascal's principle, how is pressure transmitted in a fluid?
  - b. **Explaining** How does Pascal's principle help explain the behavior of the Cartesian diver?
  - c. **Calculating** Suppose you apply a 10-N force to a 10-cm<sup>2</sup> piston in a hydraulic device. If the force is transmitted to another piston with an area of 100 cm<sup>2</sup>, by how much will the force be multiplied?

2. a. **Defining** What is a hydraulic system?
- b. **Explaining** How does a hydraulic system work?
- c. **Sequencing** Describe what happens in the brake system of a car from the time a driver steps on the brake pedal to the time the car stops.

**Writing in Science**

**Cause-and-Effect Letter** You are a mechanic who fixes hydraulic brakes. A customer asks you why his brakes do not work. When you examine the car, you notice a leak in the brake line and repair it. Write a letter to the customer explaining why a leak in the brake line caused his brakes to fail.



# Bernoulli's Principle

**CALIFORNIA**
**Standards Focus**

**S 8.2.e** Students know that when the forces on an object are unbalanced, the object will change its velocity (that is, it will speed up, slow down, or change direction).

- How is fluid pressure related to the motion of a fluid?
- What are some applications of Bernoulli's principle?

**Key Terms**

- Bernoulli's principle
- lift

**Lab zone**
**Standards Warm-Up**
**Does the Movement of Air Create Unbalanced Forces?**

1. Use your thumb and forefinger to hold a sheet of paper by the corners.
2. Hold the paper just below your mouth, so that its edge is horizontal and the paper hangs down.
3. Blow across the top of the paper.
4. Repeat this several times, blowing harder each time.

**Think It Over**

**Inferring** On what side of the paper is the force greater? How do you know?



In December 1903, Wilbur and Orville Wright brought an odd-looking vehicle to a deserted beach in Kitty Hawk, North Carolina. People had flown in balloons for more than a hundred years, but the Wright brothers' goal was something no one had ever done before. They flew a plane that was heavier (denser) than air! They had spent years experimenting with different wing shapes and surfaces, and they had carefully studied the flight of birds. Their first flight at Kitty Hawk lasted just 12 seconds. The plane flew more than 36 meters and made history.

What did the Wright brothers know about flying that allowed them to construct the first airplane? And how can the principles they used explain how a jet can fly across the country? The answer has to do with fluid pressure and how a moving fluid can create an unbalanced force.

◀ On December 17, 1903, the Wright brothers' plane *Flyer* flew for the first time.





### Faucet Force

1. Hold a plastic spoon loosely by the edges of its handle so it swings freely between your fingers.
2. Turn on a faucet to produce a steady stream of water. Predict what will happen if you touch the bottom of the spoon to the stream of water.
3. Test your prediction. Repeat the test several times.



**Developing Hypotheses** Use your observations to develop a hypothesis explaining why the spoon moved as it did.

## Pressure and Moving Fluids

So far in this chapter, you have learned about fluids that are not moving. What makes a fluid flow? And what happens to fluid pressure when a fluid moves?

**Fluid Motion** A fluid tends to flow from an area of high pressure to an area of low pressure. This happens, for example, when you sip a drink from a straw. When you start to sip, you remove the air from the straw. This creates an area of low pressure in the straw. The higher air pressure pushing down on the surface of your drink forces the drink up into the straw.

**Bernoulli's Principle** In the 1700s, Swiss scientist Daniel Bernoulli (bur NOO lee) discovered that the pressure of a moving fluid is different than the pressure of a fluid at rest. **Bernoulli's principle** states that the faster a fluid moves, the less pressure the fluid exerts.

If you did the Standards Warm-Up, you saw that air moving over the paper caused the paper to rise. Bernoulli's principle explains the behavior of the paper. **Bernoulli's principle states that as the speed of a moving fluid increases, the pressure exerted by the fluid decreases.** The air above the paper moves, but the air below the paper does not. The moving air exerts less pressure than the still air. As a result, the still air exerts greater pressure on the bottom of the paper, creating an unbalanced force which pushes the paper up.

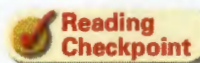

**Reading  
Checkpoint**

What is Bernoulli's principle?

FIGURE 16

### Making Air Move

Blowing air quickly between two cans lowers the air pressure between them. Higher pressure exerted by the still air to either side pushes the cans toward each other.

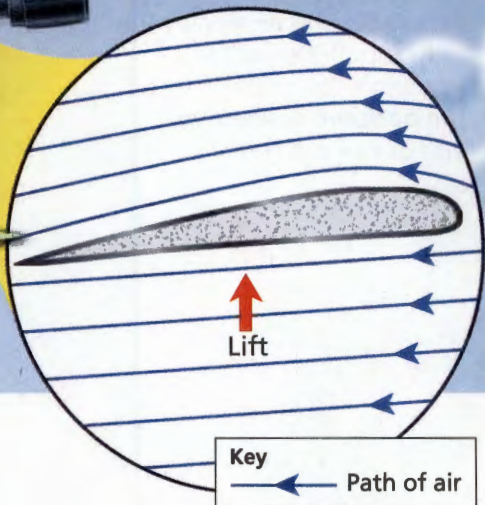





**FIGURE 17**  
**Airplane Wing**  
 An airplane wing is designed to produce an upward force for a plane in flight.  
**Interpreting Diagrams** Why is the pressure lower above the wing?

Air moves faster above the wing, creating an area of lower pressure.



## Applying Bernoulli's Principle

The Wright brothers understood Bernoulli's principle. They used it when they built their plane. 🚀 **Bernoulli's principle helps explain how planes fly. It also helps explain how an atomizer works, why smoke rises up a chimney, and how a flying disk glides through the air.**

**Objects in Flight** Bernoulli's principle is one factor that helps explain flight—from a small kite to a huge airplane. Objects can be designed so that their shapes cause air to move at different speeds above and below them. If the air moves faster above the object, fluid pressure pushes the object upward. If the air moves faster below the object, fluid pressure pushes it downward.

Because of its design, the wing of an airplane produces **lift**, or an upward force. Look at Figure 17 to see the design of a wing. Both the slant and the shape of the wing are sources of lift. Because the wing is slanted, the wing forces the air downward as the plane moves. The air exerts an equal and opposite force on the wing and pushes it upward. This unbalanced upward force helps an airplane to take off.

The curved shape of a wing also gives an airplane lift. Because the top of the wing is curved, air moving over the top has a greater speed than air moving under the bottom. As a result, the air moving over the top exerts less pressure than the air below. The difference in air pressure above and below the wing creates lift.

**Go Online**  
 SCI LINKS<sup>SM</sup> NSTA  
 For: Links on Bernoulli's principle  
 Visit: [www.SciLinks.org](http://www.SciLinks.org)  
 Web Code: scn-1334

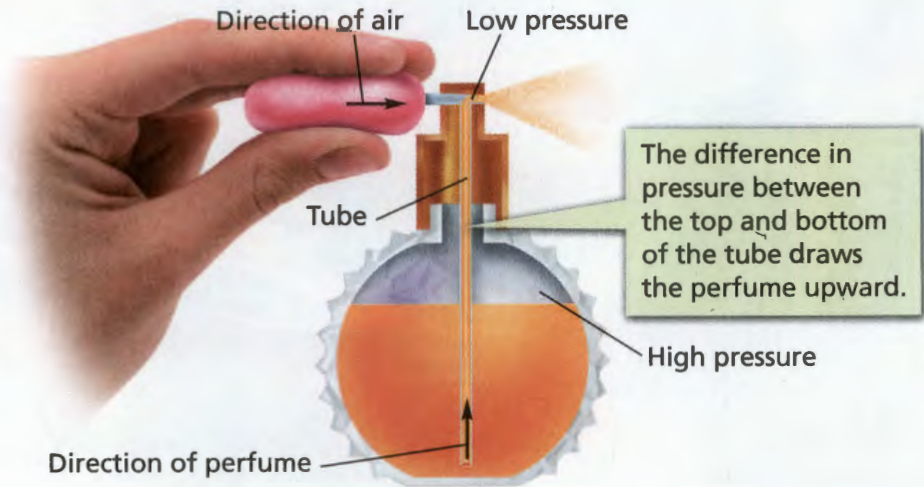

FIGURE 18

### Perfume Atomizer

An atomizer is an application of Bernoulli's principle.

**Applying Concepts** Why is the perfume pushed up and out of the flask?



**Atomizers** Bernoulli's principle can help you understand how the perfume atomizer shown in Figure 18 works. When you squeeze the rubber bulb, air moves quickly past the top of the tube. The moving air lowers the pressure at the top of the tube. The greater pressure in the flask pushes the liquid up into the tube. The air stream breaks the liquid into small drops, and the liquid comes out as a fine mist. In a similar way, pressure differences in the carburetors of older gasoline engines push gasoline up a tube. There, the gasoline combines with air to create the mixture of air and fuel that runs the engine.

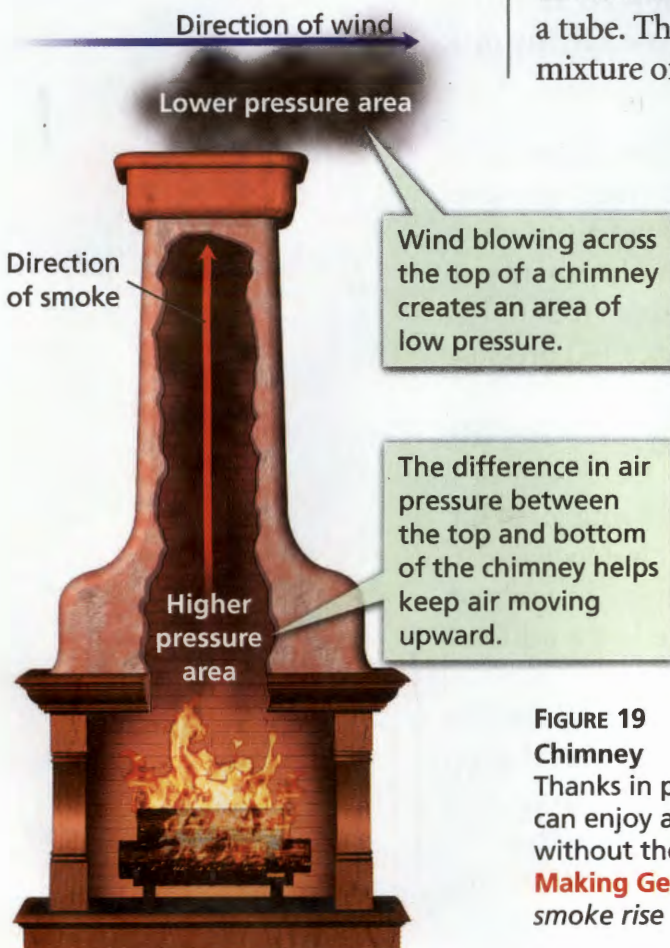

**Chimneys** You can sit next to a fireplace enjoying a cozy fire thanks in part to Bernoulli's principle. Smoke rises up the chimney partly because hot air rises, and partly because it is pushed. Wind blowing across the top of a chimney lowers the air pressure there. The higher pressure at the bottom pushes air and smoke up the chimney. Smoke will rise faster in a chimney on a windy day than on a calm day.



**Reading Checkpoint** How does an atomizer work?

FIGURE 19

### Chimney

Thanks in part to Bernoulli's principle, you can enjoy an evening by a warm fireplace without the room filling up with smoke.

**Making Generalizations** Why does the smoke rise up the chimney?



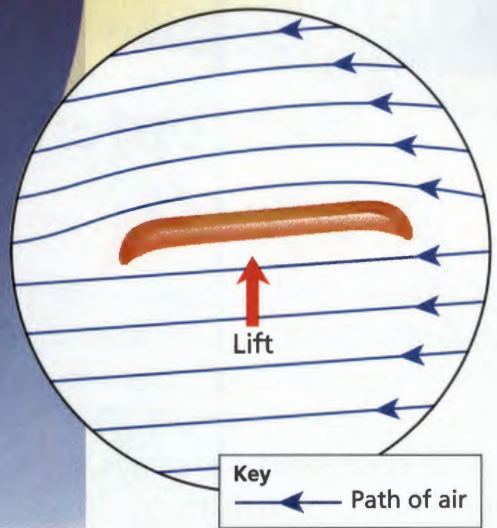

**Flying Disks** Did you ever wonder what allows a flying disk to glide through the air? The upper surface of a flying disk is curved like an airplane wing. Bernoulli's principle explains that the faster-moving air following the disk's curved upper surface exerts less pressure than the slower-moving air beneath it. A net force acts upward on the flying disk, creating lift. Tilting the disk slightly toward you as you throw it also helps to keep it in the air. A tilted disk pushes air down. The air exerts an equal and opposite force on the disk, pushing it up. The spinning motion of a flying disk keeps it stable as it flies.

**FIGURE 20**

**Flying Disk**

Like an airplane wing, a flying disk uses a curved upper surface to create lift. **Comparing and Contrasting** How does a flying disk differ from an airplane wing?

## Section 4 Assessment

S 8.2.e, E-LA: Reading 8.2.0

**Target Reading Skill Sequence** Create a flowchart to explain how an atomizer works.

**Reviewing Key Concepts**

1. a. **Reviewing** How can you make fluid flow up a straw?  
 b. **Summarizing** What does Bernoulli's principle say about the pressure exerted by a moving fluid?  
 c. **Applying Concepts** You are riding in a car on a highway when a large truck speeds by you. Explain why your car is pushed toward the truck.
2. a. **Listing** List four applications of Bernoulli's principle.  
 b. **Explaining** Why does the air pressure above an airplane wing differ from the pressure below it? How is this pressure difference involved in flight?  
 c. **Relating Cause and Effect** How could strong winds from a hurricane blow the roof off a house?

**Lab zone**

### At-Home Activity

**Paper Chimney** With a family member, see how a chimney works by using a paper cup and a hair dryer. Cut up several small pieces of tissue and place them in the bottom of a paper cup. Hold on to the paper cup with one hand. With your other hand, use the hair dryer to blow cool air across the top of the cup. Explain to your family member how Bernoulli's principle explains how the chimney works.



## Helicopters



Most aircraft are like eagles—they take off majestically, glide among the clouds, and land with ease. But helicopters are the hummingbirds of aircraft. They can fly forward, backward, sideways, and up and down. They can stop abruptly and hover in midair. In fact, helicopters can fly circles around other types of aircraft.

### Science in Action

On the top of a helicopter are large blades that turn rapidly. These blades are curved on top like the wings of an airplane. Air flowing over the curved blades helps cause lift—the upward force for the helicopter—just as air flowing over wings helps cause lift for most airplanes. Action and reaction forces as described by Newton's third law of motion also play a role in causing lift. As the tilted blades push down on the air, the air pushes up on the blade.

As the main rotor spins, the reaction force pushes the helicopter's body in the opposite direction. If not for the tail rotor, the body would spin too.

**Main Rotor**  
The main rotor turns the blades and controls their angle.

**Blades**  
Air flows over the curved, rotating blades. Along with action and reaction forces, this helps to give the helicopter lift.

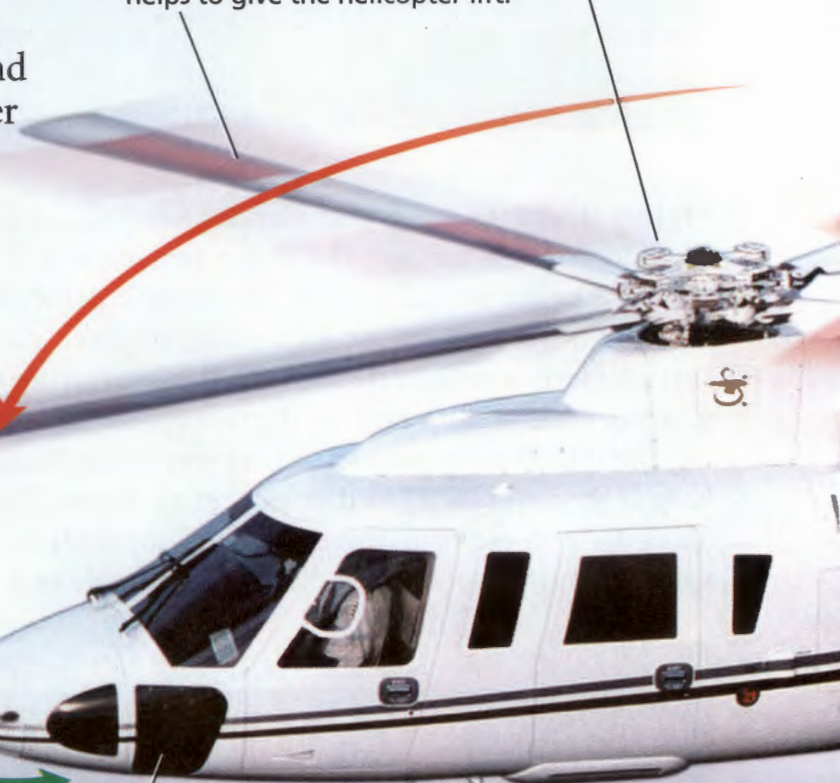

**Hand Controls and Foot Pedals**  
These controls are connected to the main rotor. The collective control guides the helicopter up or down. The cyclic control guides the helicopter forward, backward, or sideways. The foot pedals allow the helicopter to rotate in tight circles.



Air flowing over the curved blades helps create lift.

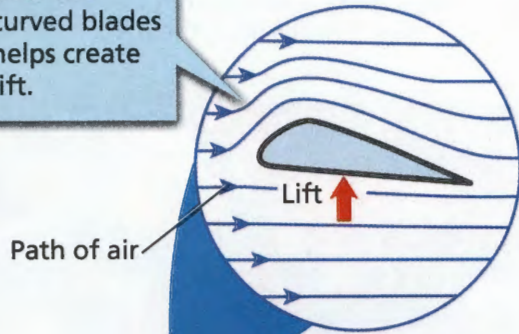

Path of air

Lift ↑

## The Aircraft of Choice—Or Not?

Helicopters can hover and land nearly anywhere. So they are often the aircraft of choice in emergency situations. They are used in search and rescue missions, in fighting forest fires, and in speeding injured people to the hospital. Construction companies also use helicopters to raise heavy equipment.

Despite these benefits, there are constraints to using helicopters. Compared to an airplane, a helicopter must refuel more often and can remain in the air for less time. Another constraint is that a helicopter cannot transport heavy equipment over long distances or carry large numbers of people.



Engine

The engine gives the main rotor power to spin the blades.

Tail Rotor

The force of the tail rotor prevents the helicopter's body from spinning by pushing against the reaction force of the main rotor.

## Weigh the Impact

### 1. Identify the Need

What advantages do helicopters have over airplanes?

### 2. Research

Using the Internet, research how helicopters are used in national parks, such as Yellowstone National Park. Choose one helicopter mission. Make notes on the mission's difficulty level, purpose, location, procedures, and outcome.

### 3. Write

Suppose you are a park ranger. Use your notes to write a report to your supervisor explaining why a helicopter was or was not the best technology to use for this mission.

**Go Online**  
PHSchool.com

For: More on helicopters  
Visit: PHSchool.com  
Web Code: cgh-3030



## The **BIG Idea**

If an object is less dense than a fluid, it will float in the fluid. If an object is more dense than a fluid, it will sink in the fluid.

### 1 Pressure

#### Key Concepts

S 8.8.d, 8.9.f

- The amount of pressure you exert depends on the area over which you exert a force.
- Pressure =  $\frac{\text{Force}}{\text{Area}}$
- In a fluid, all of the forces exerted by the individual particles combine to make up the pressure exerted by the fluid.
- Atmospheric pressure decreases as your elevation increases.
- Water pressure increases as depth increases.

#### Key Terms

pressure  
pascal  
fluid  
barometer

### 2 Floating and Sinking

#### Key Concepts

S 8.8.c, 8.8.d

- Density =  $\frac{\text{Mass}}{\text{Volume}}$
- By comparing densities, you can predict whether an object will float or sink in a fluid.
- The buoyant force acts in the direction opposite to the force of gravity, so it makes an object feel lighter.

#### Key Terms

density  
buoyant force  
Archimedes' principle



### 3 Pascal's Principle

#### Key Concepts

S 8.8.c

- When force is applied to a confined fluid, the change in pressure is transmitted equally to all parts of the fluid.
- A hydraulic system multiplies force by applying the force to a small surface area. The increase in pressure is then transmitted to another part of the confined fluid, which pushes on a larger surface area.

#### Key Terms

Pascal's principle  
hydraulic system

### 4 Bernoulli's Principle

#### Key Concepts

S 8.2.e

- Bernoulli's principle states that as the speed of a moving fluid increases, the pressure exerted by the fluid decreases.
- Bernoulli's principle helps explain how planes fly. It also helps explain how an atomizer works, why smoke rises up a chimney, and how a flying disk glides through the air.

#### Key Terms

Bernoulli's principle  
lift



## Target Reading Skill

**Sequence** Create a flowchart that shows how a hydraulic device multiplies force.

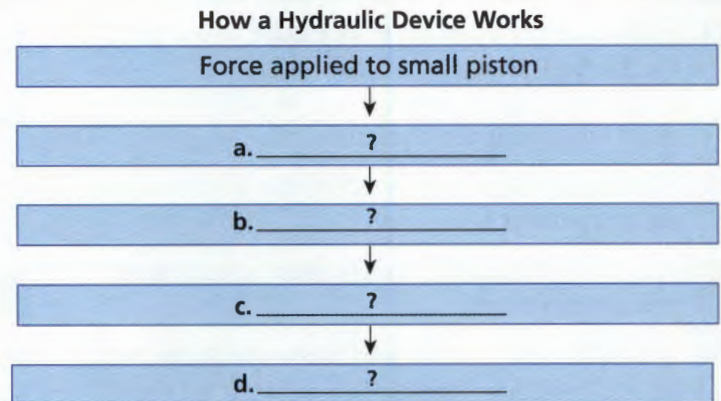

## Reviewing Key Terms

Choose the letter of the best answer.

- If you divide the force exerted on a surface by the total area of the surface, you will know
  - density.
  - pressure.
  - lift.
  - buoyant force.
- If you divide the mass of an object by its volume, you also know the object's
  - mass.
  - weight.
  - density.
  - pressure.
- The weight of an object that floats has the same value as the
  - object's density.
  - object's mass.
  - object's volume.
  - buoyant force.
- The concept that an increase in pressure on a confined fluid is transmitted equally to all parts of the fluid is known as
  - Pascal's principle.
  - Bernoulli's principle.
  - Archimedes' principle.
  - Newton's third law.
- The concept that the pressure in a fluid decreases as the speed of the fluid increases is known as
  - Pascal's principle.
  - Bernoulli's principle.
  - Archimedes' principle.
  - Newton's first law.

Complete the following sentences so that your answers clearly explain the key terms.

- If you stand on one foot, you increase the **pressure** you exert on the ground, because \_\_\_\_\_.
- Whether an object will float or sink in a fluid depends on its **density**, which is defined as \_\_\_\_\_.
- A submerged object is easier to lift due to the **buoyant force**, which is \_\_\_\_\_.
- A ship is able to float on the surface of the ocean because of **Archimedes' principle**, which states that \_\_\_\_\_.
- An airplane is able to fly partly due to **Bernoulli's principle**, which states that \_\_\_\_\_.

## Writing in Science

**News Report** Suppose that you are a newspaper journalist on the day after the Titanic sank. Write a news report that tells what happened. Explain how the buoyancy of a ship is affected when it fills with water. Include information about the various fluid forces involved.

### Video Assessment

Discovery Channel School

Forces in Fluids



# Review and Assessment

## Checking Concepts

- How does the amount of pressure you exert on the floor when you are lying down compare with the amount of pressure you exert when you are standing up?
- Why aren't people crushed by the air pressure they experience?
- Why do you seem to weigh more in air than you do in water?
- In a hydraulic system, why is the force exerted on a small piston multiplied when it acts on a larger piston?
- Name two hydraulic systems that an auto mechanic would know well.
- Why is air pressure at the top of a chimney less than air pressure at the bottom?

## Thinking Critically

- Making Generalizations** How does the water pressure change at each level in the jug below? How can you tell?



- Problem Solving** You have two fluids of unknown density. Suggest a method to determine which is denser, without mixing the two fluids.
- Developing Hypotheses** A sphere made of steel is put in water and, surprisingly, it floats. Develop a possible explanation for this observation.
- Applying Concepts** One method of raising a sunken ship to the surface is to inflate large bags or balloons inside its hull. Explain why this procedure could work.

## Math Practice

- Area** The cover of your textbook measures about  $28 \text{ cm} \times 22 \text{ cm}$ . Find its area.
- Area** A dollar bill measures about  $15.9 \text{ cm} \times 6.7 \text{ cm}$ . The Chinese yuan note measures  $14.5 \text{ cm} \times 7.0 \text{ cm}$ . Which currency uses a larger bill?

## Applying Skills

The illustration shows an object supported by a spring scale, both in and out of water. Use the illustration to answer Questions 23–25.

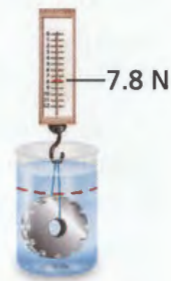

- Inferring** Why is there a difference between the weight of the object in air and its measured weight in water?
- Calculating** What is the buoyant force acting on the object?
- Drawing Conclusions** What can you conclude about the water above the dotted line?

Lab zone

## Standards Investigation

**Performance Assessment** Test your boat to make sure it does not leak. Display the diagrams of different designs you tried and the observations and data you recorded for each design. Then demonstrate for the class how the boat floats. Point out to your classmates the features you used in your final design.



Choose the letter of the best answer.

- You place a block of wood into a beaker of water and it floats. What can you say about the buoyant force on the block?
  - It is equal to the block's weight.
  - It is less than the block's weight.
  - It is greater than the block's weight.
  - It is equal to the weight of the surrounding water.

**S 8.8.c**
- You carefully drop a stone into a beaker full of water. The stone sinks to the bottom and water spills out. What can you say about the weight of the displaced water?
  - It is greater than the weight of the stone.
  - It is equal to the weight of the stone.
  - It is less than the weight of the stone.
  - It is equal to the weight of the water still in the beaker.

**S 8.8.c**

Use the photos below to answer Question 3.

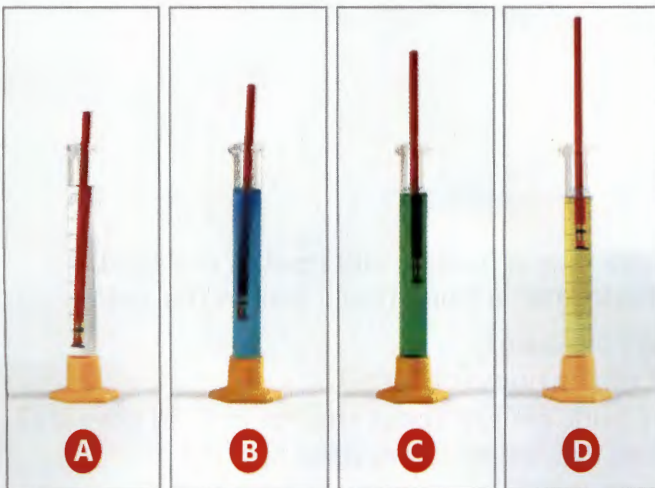

- You place a pencil hydrometer into four different unknown liquids, labeled A, B, C, and D. The hydrometer floats at different levels in the four liquids. Which liquid is the most dense?
  - Liquid A
  - Liquid B
  - Liquid C
  - Liquid D

**S 8.8.d**

- Why does an airplane rise in the air?
  - It experiences a buoyant force because it is less dense than the air.
  - The moving air above and below the wings creates an unbalanced force that pushes the airplane up.
  - The air pressure above the wings is greater than the air pressure below the wings.
  - The airplane's cabin is pressurized.

**S 8.2.e**
- You observe that a chunk of tar sinks in puddles of rainwater but floats on the ocean. An experiment to explain the behavior of the tar should measure
  - the difference between atmospheric pressure and water pressure.
  - the densities of fresh water, salt water, and tar.
  - the height from which the chunk of tar is dropped.
  - the depth of each type of water.

**S 8.8.d**
- A helium balloon rises because the helium
  - is hotter than the surrounding air.
  - is colder than the surrounding air.
  - is less dense than the surrounding air.
  - is more dense than the surrounding air.

**S 8.8.d**

### Apply the BIG Idea

- Explain why objects experience a buoyant force when immersed in a fluid. How can you find the value of the buoyant force? How can knowing the density of an object and a fluid help you predict if the object will float or sink in the fluid?
 

**S 8.8**



# Motion, Forces, and Energy

## Unit 3 Review



### Chapter 9

#### Motion and Energy

##### The BIG Idea

You can describe the motion of an object by its position, speed, direction, and acceleration.

- When is an object in motion?
- How do you calculate speed?
- How do you calculate acceleration?
- What affects an object's kinetic energy and potential energy?



### Chapter 10

#### Forces

##### The BIG Idea

An unbalanced force will cause a change in an object's velocity.

- How do balanced and unbalanced forces affect velocity?
- Why do objects accelerate during free fall?
- What is Newton's second law of motion?
- What is Newton's third law of motion?
- What keeps a satellite in orbit?



### Chapter 11

#### Forces in Fluids

##### The BIG Idea

If an object is less dense than a fluid, it will float in the fluid.  
If an object is more dense than a fluid, it will sink in the fluid.

- How do fluids exert pressure?
- What is the effect of the buoyant force?
- What does Pascal's principle say about change in fluid pressure?
- How is fluid pressure related to the motion of a fluid?



# Unit 3 Assessment



## Connecting the BIG Ideas

Welcome to the Summer Triathlon. Do you have what it takes to compete in all three athletic events?

Today's triathlon will begin with a 750-m swim. We've set up buoys floating in the water so you can follow the path of the race properly. Don't swim too far away from these floating markers, or you'll go off course and have to get back on track!

Next you will cycle 20 km. When you get to the finish line, remember to brake as quickly as possible so you can start the last leg of the event.

Finally, you will have to run 5 km along the edge of the lake. The view is beautiful, but don't forget to keep your eye on the prize. You'll have to turn around at the halfway mark and change direction because the race finishes at the same bridge where it begins.

Remember to pace yourself! And at the end, we have a special surprise for you. All athletes who complete the triathlon win a medal!

1. It took you half an hour to run the final 5 km of the triathlon. Using that information, what can you find? (Chapter 9)
  - a. average speed
  - b. instantaneous speed
  - c. acceleration
  - d. direction
2. At the end of the bicycle race, what kind of friction do you rely on when you use your hand brakes to come to a stop? (Chapter 10)
  - a. static friction
  - b. sliding friction
  - c. rolling friction
  - d. fluid friction
3. Which of the following is a possible density for the buoys floating in the lake? (Chapter 11)
  - a.  $0.9 \text{ g/cm}^3$
  - b.  $9 \text{ g/cm}^3$
  - c.  $90 \text{ g/cm}^3$
  - d.  $900 \text{ g/cm}^3$



4. **Summary** Write a paragraph that describes the different forces you experienced while running in the triathlon. Did these forces cause changes in your motion? Explain.